

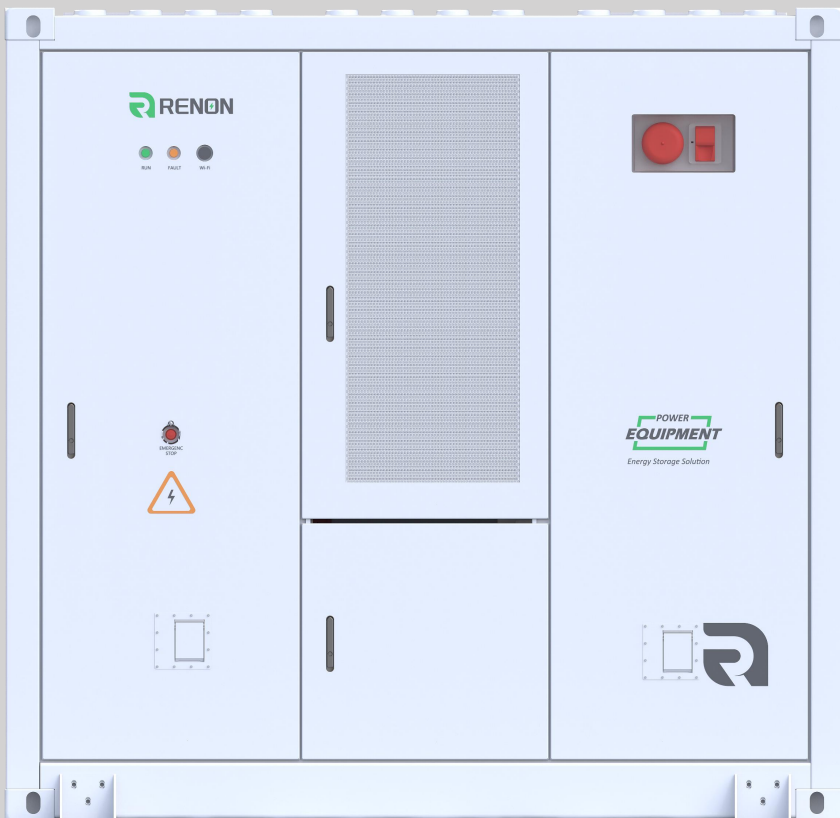

# Operation and Maintenance

**R-SM1672860A1-US**

**Smart Matrix A**



○ E-mail: [support@renon-usa.com](mailto:support@renon-usa.com)

**Buyer:**

\_\_\_\_\_

**Supplier:**

\_\_\_\_\_

\_\_\_\_\_

**2025 1<sup>ST</sup> EDITION**

© Renon Power USA LLC.  
All rights reserved. Specifications are subject to change without notice.

# Renon Power

## We Care About Sustainability

With our own R&D team and automatic production factory, we are dedicated to delivering innovative, reliable, and affordable energy storage solutions to global customers.

At Renon, we believe that sustainable energy is the future. We are passionate about reducing carbon emissions and preserving our planet for future generations. That's why we invest heavily in research and development, leveraging the latest technologies to design and manufacture energy storage systems that are efficient, scalable, and adaptable.

Our products are designed to meet the needs of a wide range of applications, from residential and commercial buildings to industrial facilities and utility-scale projects. Whether you're looking to reduce your energy bills, increase your energy independence, or support your sustainability.

Our commitment to quality and customer satisfaction is unwavering. We work closely with our clients to understand their unique needs and provide customized solutions that meet or exceed their expectations. We also provide comprehensive technical support, maintenance, and warranty services to ensure that our customers get the most out of their investment.

Join us on our mission to make renewable energy within reach.

---

PROVIDE **INNOVATIVE,**  
**RELIABLE, AND**  
**AFFORDABLE ENERGY**  
**STORAGE SOLUTIONS**  
**TO CUSTOMERS**  
**WORLDWIDE.**

---



## CONTENTS

<b>1. GENERAL PART</b> .....	<b>- 1 -</b>
<b>2. SAFETY REGULATIONS</b> .....	<b>- 1 -</b>
<b>3. ROUTINE INSPECTION</b> .....	<b>- 2 -</b>
<b>4. SPECIAL INSPECTION</b> .....	<b>- 3 -</b>
<b>5. REGULAR MAINTENANCE</b> .....	<b>- 4 -</b>
5.1 OVERALL MAINTENANCE OF BATTERY CONTAINER .....	- 4 -
5.2 BATTERY SYSTEM MAINTENANCE .....	- 5 -
5.3 PCS MAINTENANCE .....	- 5 -
5.4 FIRE SUPPRESSION SYSTEM MAINTENANCE .....	- 6 -
THE VALIDITY PERIOD OF THE COMPONENTS IS LISTED AS FOLLOWS. ....	- 6 -
5.5 LIQUID COOLING SYSTEM MAINTENANCE .....	- 6 -
<b>6. TROUBLESHOOTING</b> .....	<b>- 6 -</b>
6.1 FAULT ALARM SYSTEM .....	- 6 -
6.2 EXPORT LOGS .....	- 7 -
6.3 FAULT RESOLUTION .....	- 7 -
6.4 LOCAL EMS UPGRADE PROCEDURE .....	- 7 -
<b>7. DISMANTLING AND SCRAPPING</b> .....	<b>- 8 -</b>
7.1 REMOVE THE ENERGY STORAGE SYSTEM .....	- 8 -
7.2 DISPOSAL OF ENERGY STORAGE SYSTEM .....	- 8 -
<b>8. REVISION TABLE</b> .....	<b>- 9 -</b>
<b>APPENDIX 1 DETECTION METHOD AND DETECTION ITEMS OF COOLANT</b> .....	<b>- 10 -</b>

## 1. General Part

This Operation and Maintenance Manual applies to the **Renon Smart Matrix A (Product Model: R-SM1672860A1-US)** Battery Energy Storage System (BESS). This manual outlines the operation guidelines and maintenance scope for the Smart Matrix A system, ensuring safe and efficient operation and maintenance practices throughout its entire lifecycle.

All personnel must thoroughly review and strictly comply with this manual prior to operating the equipment or performing maintenance activities. For procedures not specified herein, please contact Renon.

## 2. Safety Regulations

	<p>1. Do not open the door of the battery container for maintenance in rainy, humid, windy or thunderstorm weather. The company will not be liable for any loss caused by failure to avoid it.</p> <p>2. When performing regular maintenance on the battery Container, please power down the BESS. Operating the equipment with power may cause damage or cause electric shock hazard. There is no such requirement during daily inspection.</p> <p>3. In case of emergency, use the emergency stop button to power down the equipment.</p>
---	---

To safely and effectively maintain the system, maintenance personnel should carefully read and comply with the following safety requirements:

- a. Maintenance personnel must hold a certificate of electrician and pass the professional training before being qualified to work.
- b. Safety precautions must be observed, necessary tools must be used and personal protective equipment must be worn.
- c. Metal jewelry such as jewelry or watches is strictly prohibited.
- d. Under no circumstances is it allowed to touch the high voltage positive and negative electrodes of the energy storage system.
- e. When cleaning, do not use water to clean directly, and use a vacuum cleaner when necessary.
- f. When plugging in the cable, the operation should be standardized, and no brute force or violent operation should be used.
- g. After maintenance, clean up the tools and materials in time to check whether there are any metal objects left inside or on top of the equipment.

### 3. Routine Inspection

This inspection form is used for the routine safety inspection of energy storage container. The inspection frequency is determined based on a comprehensive consideration of risk assessment, manufacturer recommendations, industry standards, and practical operational experience.

The table below provides our recommended inspection frequencies for different scenarios, where "Manned Sites" refer to locations with frequent human activity and relatively high dynamic risks; while "Unmanned Sites" indicates unmanned locations with relatively static risks.

However, the specific frequency is ultimately determined by the user.

Scenarios	Manned Sites	Unmanned Sites
The first 3 months of new equipment put into operation	2-3 times per week	Weekly
After stable operation	Weekly	Bi-weekly
With the use of cloud platforms or remote monitoring for equipment inspection	Bi-weekly	Monthly

Please check and record the data according to the following items.

No.	Inspection items	Requirements
1	Container	1) No flammable object on the top of the battery container, no foreign matter accumulation, and no foreign matter blocking the door and heat dissipation positions around the container; 2) The exterior and structure of the container are intact, without damage, paint loss, oxidation, rust, water leakage, etc.; 3) The container doors and locks open smoothly, and the door seals are free from aging or damage; 4) The mounting points between the container and the foundation/channel steel are secure, with no signs of corrosion; 5) No cracking or settlement of the foundation of the container; 6) The temperature and humidity are within the normal operating range (operating temperature: -30~55°C, operating humidity: 5~95% RH), the liquid cooling unit, ventilation and other temperature adjustment equipment are running normally, and no odor in the room; 7) The bottom sealing is intact, and measures to prevent small animals are in place; 8) The nameplate is clear and identifiable; 9) The indicator lights on the door are intact and function normally.
2	Battery System	1) No abnormal smoke, vibration and sound; 2) Batteries are intact without damage, swelling, deformation, or leakage; 3) Battery compartment grounding is intact, with no rust or loosening of grounding flat iron; 4) Battery voltage and temperature collection lines are reliably connected and operating normally; 5) BMS parameters displayed via EMS are normal, battery voltage and temperature are within acceptable ranges, and there are no alarm signals;

3	Electrical Connection	<ol style="list-style-type: none"> <li>1) Cable markings are clear and identifiable;</li> <li>2) Grounding of internal equipment is intact;</li> <li>3) Cable insulation is free of aging;</li> <li>4) Cable connections are free of loosening, corrosion, blackening, or other defects, and cable terminals are free of high-temperature burn marks.</li> </ol>
4	Fire Suppression System	<ol style="list-style-type: none"> <li>1) The fire suppression system is in good condition, with no damaged or missing parts.</li> <li>2) Smoke and heat detectors are functioning normally, with no abnormal alarms.</li> </ol>
5	Liquid Cooling System	<ol style="list-style-type: none"> <li>1) The chillers is clean and in good condition, with no rust, deformation, or liquid leakage;</li> <li>2) There is no leakage from the drain outlet, and the liquid cooling pipes are free of damage, leakage, or abnormal deformation;</li> <li>3) The chiller operates without abnormal vibration or noise (mainly observing the operation of the following components: compressor, fan, circulating water pump, with a noise <math>\leq 75\text{dB(A)}</math>).</li> </ol>
6	Dehumidifier	<ol style="list-style-type: none"> <li>1) The outlet pipe is free of tangles and does not bend when opening and closing the door, ensuring smooth drainage;</li> <li>2) There is no dust or foreign matter on the air outlet to prevent foreign matter from falling into the dehumidifier and causing damage.</li> </ol>
7	PCS	<ol style="list-style-type: none"> <li>1)The appearance is clean; no damage, scratches, dents, etc.;</li> <li>2) Check that the indicator light display is normal;</li> <li>3) Observe that the AC and DC side voltage and current are normal via the local EMS;</li> <li>4) Operating normally, no abnormal sound, smoke or burnt smell.</li> </ol>
8	EMS	<ol style="list-style-type: none"> <li>1) Operating normally, with normal switching between functional interfaces;</li> <li>2) Communicating normally with BMS, PCS, fire protection, and other systems;</li> <li>3) No abnormal alarm messages when reading data via the local EMS. If you have any questions, please contact Renon promptly. Do not open the Container without authorization. (Due to limited memory, data is stored for approximately 3 months, depending mainly on the data storage interval and the total number of measurement points.)</li> </ol>

#### 4. Special inspection

This inspection form is used for special safety inspection. In case of special circumstances (extreme weather, abnormal and fault after operation, new equipment put into operation, etc.), please check each item according to the following items and record the data.

Number	Special Circumstances	Inspection and Inspection Requirements
1	Extreme Weather (Severe weather events such as heavy rainfall and thunderstorms)	<ol style="list-style-type: none"> <li>1) Check whether the operating temperature and humidity are normal;</li> <li>2) Check whether the battery, PCS and terminals are overheated;</li> <li>3) Check whether the cable is too tight and the terminal is not cracked in cold weather (daily min temp<math>\leq -20^{\circ}\text{C}</math>);</li> <li>4) Increase the frequency of infrared temperature measurement in high temperature weather (daily max temp<math>\geq 35^{\circ}\text{C}</math>), and check the condensation inside the battery compartment;</li> <li>5) Check whether the grounding is normal before and after the thunderstorm season;</li> <li>6) Check whether the drainage of the dehumidifier is smooth and the air outlet is not blocked in high humidity environment.</li> </ol>

2	After Abnormality or Fault	<ol style="list-style-type: none"> <li>1) Check whether the battery case is swollen or leaking in the fault range;</li> <li>2) Focus on checking whether the fuse and connection terminals are melted or black;</li> <li>3) Retrieve the BMS fault alarm records through EMS and analyze abnormal voltage and temperature points;</li> <li>4) Retrieve and save the PCS operating data before and after the fault (such as current fluctuations) through EMS.</li> </ol>
3	New Equipment Put Into Operation or Put Back Into Operation after Major Repairs	<ol style="list-style-type: none"> <li>1) Monitor battery voltage consistency during the first charge and discharge cycle;</li> <li>2) Check for leaks in the liquid cooling pipes (simulated operation for 30 minutes);</li> <li>3) Check for abnormal noises, overheating of joints, etc. (refer to daily inspection items).</li> <li>4) When the equipment is not put into operation and the Container door is frozen, do not force it open. Use auxiliary equipment to heat and thaw it first.</li> </ol>
4	Other Types	<ol style="list-style-type: none"> <li>1) Increase the number of inspections appropriately during power protection;</li> <li>2) For defective and faulty equipment, focus on checking whether the abnormal phenomenon and defects are developing.</li> </ol>

## 5. Regular Maintenance

Regular maintenance is a kind of preventive maintenance. It means that maintenance personnel carry out periodic inspection and maintenance work during the normal operation of equipment, so as to find and eliminate alarms and potential faults in the equipment in time. The following is the recommended maintenance cycle, and the actual maintenance cycle should be adjusted according to the specific installation environment of the product.

Factors such as the scale of ESS, installation location and site environment will affect the maintenance cycle of products. If the operating environment is windy and sandy, thick dust or high salt spray area, it is necessary to shorten the maintenance cycle and increase the maintenance frequency.





### Danger

- When performing regular maintenance on the battery container, the ESS must be powered down.

### 5.1 Overall Maintenance of Battery Container

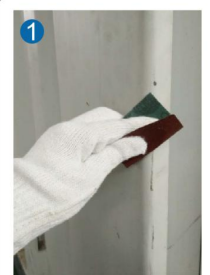
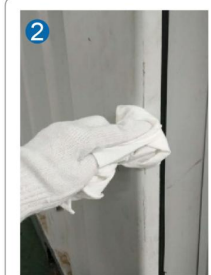
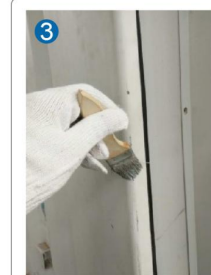
Requirement	Recommended Maintenance Period
1) Clean the top and surrounding area of the battery container, especially pay attention to clean the air inlet and outlet mesh holes, and use a vacuum cleaner when necessary (do not rinse with water) to ensure that the air can circulate freely in the container.	Every 6 months
2) Check the door panel sealing strip to confirm whether it is aging and needs to be replaced. (When the sealing strip is broken or brittle and loses its elasticity, it indicates that the sealing strip has aged).	Every 6 months
3) Check and tighten the bolts at user wiring connections (refer to the installation manual for torque).	Every 12 months
4) If stubborn stains on the surface cannot be removed by wiping, proceed as follows: <ol style="list-style-type: none"> <li>① Use sandpaper to sand the areas with paint burrs or scratches until the surface is smooth.</li> <li>② Wipe the repaired area with a cloth dampened with water or 97% alcohol to remove</li> </ol>	Depends on the specific circumstances.



<p>any surface contaminants.</p> <p>③ After the surface is completely dry, use a soft-bristled brush to apply touch-up paint to the scratched areas. Strive for an even and uniform application of the paint.</p> <div style="display: flex; justify-content: space-around;">    </div>	
<p>5) If the container's primer is damaged, exposing the base material, proceed as follows:</p> <p>① Use sandpaper to sand the damaged paint area. Remove any surface rust and burrs until a smooth surface is achieved.</p> <p>② Wipe the damaged area with a cloth dampened with water or 97% alcohol to remove surface stains and dust.</p> <p>③ After the surface is completely dry, apply a zinc-rich primer by spray to protect any exposed base material. The spray must fully cover all exposed areas.</p> <p>④ Once the primer is dry, use a soft-bristled brush to apply touch-up paint to the repaired area. Ensure the paint application is even and uniform.</p> <div style="display: flex; justify-content: space-around;">     </div>	<p>Depends on the specific circumstances.</p>

## 5.2 Battery System Maintenance

Requirement	Recommended Maintenance Period
<p>1) Perform regular charging and discharging for batteries stored under low power. (Before storage, it is recommended to adjust the battery level to 25%-40%. Continuous storage should not exceed two months, or perform maintenance every two months. Before the first use after storage, ensure full charging at least once to activate the battery system and restore optimal performance.)</p>	<p>Every 2 months</p>
<p>2) Regularly read and save BMS data via EMS.</p>	<p>Every 3 months</p>

## 5.3 PCS Maintenance

Requirement	Recommended Maintenance Period
<p>1) Check whether the PCS cable wiring is loose regularly; check whether the connection terminals and insulation are discolored or fallen off, and replace the damaged or corroded connection terminals.</p>	<p>Every 12 months</p>
<p>2) Regularly read and save the operating data of the energy storage converter via EMS.</p>	<p>Every 3 months</p>

## 5.4 Fire Suppression System Maintenance

Requirement	Recommended Maintenance Period
1) Check whether the aerosol and other components of the fire suppression system are within the validity period. (If the validity period has expired, it is recommended to replace it.)	Every 12 months

The validity period of the components is listed as follows.

Component	Quantity (per Smart Matrix A)	Validity Period
Battery	2	5
Control Module	2	7
Heat Detector	2	7
Photoelectric Smoke Detector	2	7
Flammable Gas Detector	2	5
Exhaust Fan	2	7
Motorized Louvre	2	7

## 5.5 Liquid Cooling System Maintenance

Requirement	Recommended Maintenance Period
1) Use a soft brush or cotton cloth to clean dust and dirt from the unit (especially those with front air intake/rear air outlet structures). Do not use high-pressure water jets.	Every 12 months
2) Regularly inspect the coolant. If there is an abnormality in the coolant indicators (including pH value, electrical conductivity, turbidity, and pressure), it can be restored to normal levels by replenishing or replacing the coolant. (Refer to <b>Appendix 1: Detection Method and Detection Items of Coolant</b> for detail)  <b>Note:</b> Please consult the Renon for specific operational guidance before supplementing or replacing the coolant.	Every 6 months
3) Check regularly whether the electrical cables and terminals are loose, whether the power cables are aging and damaged, abnormal heating and other abnormal conditions. If necessary, tighten the cables and terminals with a screwdriver, and replace the power cables.	Every 6 months

## 6. Troubleshooting

### 6.1 Fault Alarm System

The EMS fault alarm system has 4 severity levels:

- **L1 Alarm:** Critical faults that require manual intervention. The system cannot automatically recover. After the fault is cleared, a manual restart of the equipment is required to resume normal operation.
- **L2 Alarm:** Self-recoverable faults. After the fault condition disappears, the system can automatically recover and resume normal operation without manual intervention.

- **L3 Alarm:** Warning alerts. Some of these may cause the equipment to operate in a derated state.
- **L4 Alarm:** Informational notes. Can be safely ignored. For example, the BMS - SOC High L4 Alarm is a normal operational prompt when the battery is fully charged.

The "Alarm" menu interface displays warning messages from all components during the operation of the ESS. The displayed information includes: date/time, affected component, alarm device, alarm details, and operational status.

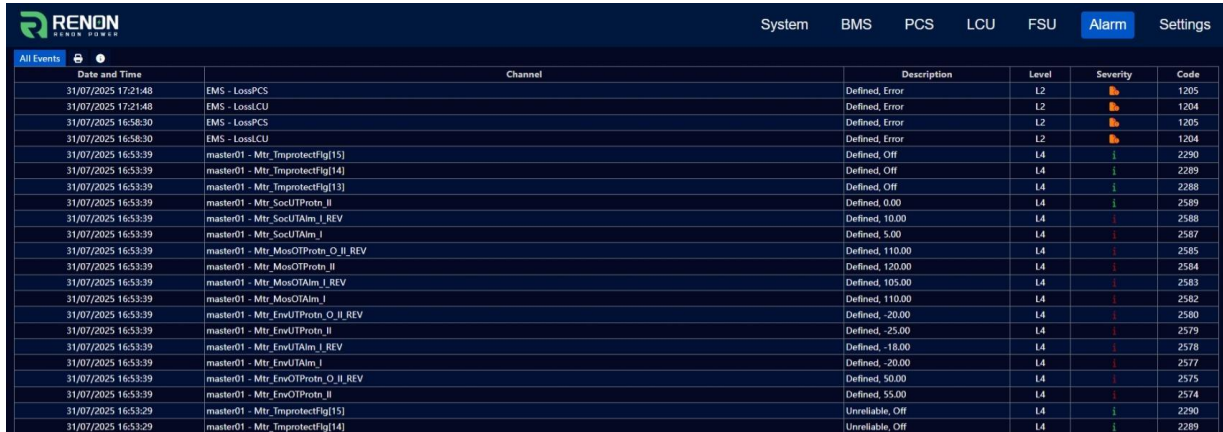

Date and Time	Channel	Description	Level	Severity	Code
31/07/2025 17:21:48	EMS - LossPCS	Defined_Error	L2	🔴	1205
31/07/2025 17:21:48	EMS - LossLCU	Defined_Error	L2	🔴	1204
31/07/2025 16:58:30	EMS - LossPCS	Defined_Error	L2	🔴	1205
31/07/2025 16:58:30	EMS - LossLCU	Defined_Error	L2	🔴	1204
31/07/2025 16:53:39	master01 - Mtr_TmprotectFig115	Defined_Off	L4	🟢	2290
31/07/2025 16:53:39	master01 - Mtr_TmprotectFig114	Defined_Off	L4	🟢	2289
31/07/2025 16:53:39	master01 - Mtr_TmprotectFig113	Defined_Off	L4	🟢	2288
31/07/2025 16:53:39	master01 - Mtr_SocUTPrtn_II	Defined_0,00	L4	🟢	2589
31/07/2025 16:53:39	master01 - Mtr_SocUTAlm_I_REV	Defined_10,00	L4	🟢	2588
31/07/2025 16:53:39	master01 - Mtr_SocUTAlm_I	Defined_5,00	L4	🟢	2587
31/07/2025 16:53:39	master01 - Mtr_MosOTPrtn_O_II_REV	Defined_110,00	L4	🟢	2585
31/07/2025 16:53:39	master01 - Mtr_MosOTPrtn_II	Defined_120,00	L4	🟢	2584
31/07/2025 16:53:39	master01 - Mtr_MosOTAlm_I_REV	Defined_105,00	L4	🟢	2583
31/07/2025 16:53:39	master01 - Mtr_MosOTAlm_I	Defined_110,00	L4	🟢	2582
31/07/2025 16:53:39	master01 - Mtr_EnvUTPrtn_O_II_REV	Defined_-20,00	L4	🟢	2580
31/07/2025 16:53:39	master01 - Mtr_EnvUTPrtn_II	Defined_-25,00	L4	🟢	2579
31/07/2025 16:53:39	master01 - Mtr_EnvUTAlm_I_REV	Defined_-18,00	L4	🟢	2578
31/07/2025 16:53:39	master01 - Mtr_EnvUTAlm_I	Defined_-20,00	L4	🟢	2577
31/07/2025 16:53:39	master01 - Mtr_EnvOTPrtn_O_II_REV	Defined_50,00	L4	🟢	2575
31/07/2025 16:53:39	master01 - Mtr_EnvOTPrtn_II	Defined_55,00	L4	🟢	2574
31/07/2025 16:53:29	master01 - Mtr_TmprotectFig115	Unreliable_Off	L4	🟢	2290
31/07/2025 16:53:29	master01 - Mtr_TmprotectFig114	Unreliable_Off	L4	🟢	2289

## 6.2 Export Logs

If a fault occurs in the operation, the logs shall be downloaded and sent to RENON for analysis. Click the "Export Log" menu to enter the system log interface. Alarm logs can be exported locally via a USB drive or remotely through the cloud platform. Both log format (.log files) and event table format (.xlsx files) are supported, containing complete alarm records and operation history.

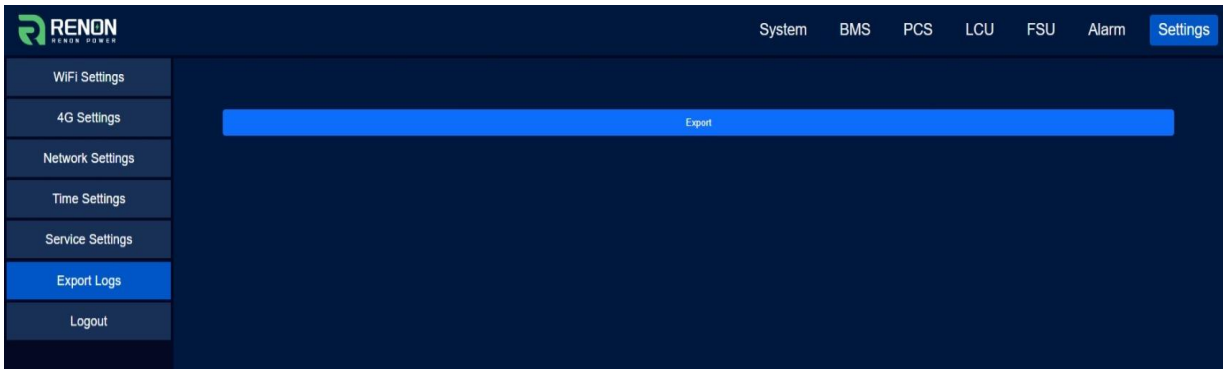

## 6.3 Fault Resolution

For detailed fault resolution methods, please contact RENON technical support personnel.

## 6.4 Local EMS Upgrade Procedure

When an upgrade to the local EMS is required, RENON will provide the corresponding software installation package. The user needs to prepare a USB flash drive in advance and copy the upgrade package onto it.



	
<p>USB Drive Format Requirement: FAT32</p>	<p>Example (Software Installation Package)</p>

## 7. Dismantling and Scrapping

### 7.1 Remove the Energy Storage System

Step 1: Open the container door.

Step 2: Perform the power down operation on the energy storage system.

Step 3: Disconnect the external power supply and communication of the energy storage system.

Step 4: Disconnect all electrical connections of the energy storage system, including AC cables, DC cables, communication cables and protective earth cables.

Step 5: Properly store the energy storage system. If the energy storage system needs to be put into use later, ensure that the storage conditions meet the requirements.

### 7.2 Disposal of Energy Storage System

Prior to decommissioning and disposal of the energy storage system, contact the Renon. The system must then be disposed of in compliance with local e-waste regulations and must not be disposed of as household waste.

Special attention must be given to battery disposal. Used batteries shall be handled in an appropriate and environmentally sound manner.

Important safety precautions include:

- 1) Do not incinerate batteries. Exposure to fire or high heat may cause rupture or explosion.
- 2) Do not disassemble, crush, or puncture batteries. The released electrolyte is corrosive and highly toxic, posing serious risks of skin irritation, eye damage, and chemical burns.
- 3) Store discarded batteries in a non-flammable, stable container until they can be properly recycled.
- 4) Do not dispose of the UPS or UPS batteries as general waste. This product contains sealed lead-acid batteries and must be handled appropriately. For detailed information, please contact your local recycling/reuse center or hazardous waste disposal facility.

## 8. Revision Table

The document revision history is tracked in the following table:

Revision Number	Date (MM/DD/YYYY)	Description
1.0	Dec 20, 2025	Initial version



## Appendix 1 Detection Method and Detection Items of Coolant

On-site rapid inspection + third-party detection can be adopted. Use rapid inspection equipment for on-site detection of all indicators (including pH value, electrical conductivity, turbidity, and pressure) every 6 months. If the indicators are abnormal, samples can be sent to a local third-party detection institution for detection.

### 1. On-site Sampling Steps for Chiller

- ① Cut off the power supply and wait for at least 1 minute.
- ② Use a drain pipe with a quick connector to connect to the drain port. For the location of the drain port, please refer to the follow figure.

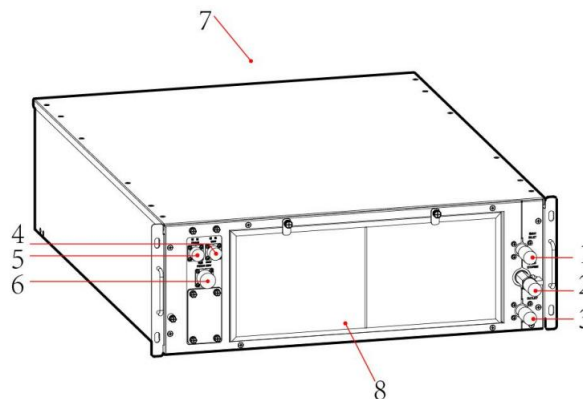

- |                    |                               |
|--------------------|-------------------------------|
| 1: Coolant inlet   | 2: Coolant filling&drain port |
| 3: Coolant outlet  | 4: COM interface              |
| 5: Debug interface | 6: Power interface            |
| 7: Air outlet      | 8: Air inlet                  |

- ③ Open the drain ball port, drain an appropriate amount of coolant as a sample, then close the port and remove the drain pipe.

### 2. On-site Detection of Coolant Metrics

Check all indicators (including pH value, electrical conductivity, turbidity, and pressure) of the coolant. If any abnormality is detected in the indicators, the sample shall be sent to a third-party testing institution for further analysis. The detection methods for each item are as follows:

#### 2.1 PH value detection

The pH value can be detected using a portable pH meter or pH test paper. The steps for testing the coolant pH with test paper are as follows:

- 1) Rinse the sample container (small and transparent container is recommended) and drain pipe with pure water. Make sure the sample container and drain pipe are dry and clean.
- 2) Take a small sample (10ml) of coolant to the container using drain pipe.
- 3) Dip one pH test strip into the coolant sample for the time specified on the test strip packaging, usually about 2 seconds.

- 4) Remove the strip from the coolant and shake it gently to remove excess liquid.
- 5) Compare the color of the pH-sensitive pad on the strip to the color chart on the strip's packaging to determine the pH level.
- 6) A pH reading greater or equal to 7 indicates that the coolant passes on this metric .

## 2.2 Electrical conductivity testing

The electrical conductivity can be tested using a portable conductivity meter or a pen-type conductivity meter. The steps for testing the coolant electrical conductivity with conductivity meter are as follows:

- 1) Rinse the electrode probe, sample container (small and transparent container is recommended) and drain pipe with pure water. Make sure the electrode probe of meter, container and drain pipe are dry and clean.
- 2) Make sure the conductivity meter is calibrated.
- 3) Take a small sample (10-100ml, depend on the size of the container) of coolant to the container using drain pipe.
- 4) Put the electrode probe into the coolant sample, make sure the electrode is completely immersed into the liquid.
- 5) Wait the reading value is stable and read the value.
- 6) An electrical conductivity reading between 2000 and 4000  $\mu\text{S}/\text{cm}$  indicates that the coolant passes on this metric.

## 2.3 Turbidity

The turbidity can be detected using a portable turbidity meter or a turbidity test tube. The steps for testing the coolant turbidity with turbidity meter are as follows:

- 1) Rinse the probe, sample container (small and transparent container is recommended) and drain pipe with pure water. Make sure the probe of meter, sample container and drain pipe are dry and clean.
- 2) Make sure the turbidity meter is calibrated.
- 3) Take a small sample (10-100ml, depend on the size of the container) of coolant to the container using drain pipe.
- 4) Place the turbidity meter's sensor probe into the coolant sample in the container.
- 5) Wait the reading value is stable and read the value.
- 6) A turbidity reading smaller than 5 NTU indicates that the coolant passes on this metric.

## 2.4 Pressure

Pressure readings can be accessed through the EMS. The outlet pressure (outpress) and inlet pressure (inpress) values of the cooling system are available in the LCU menu. If both the outpress and inpress values are below 10 bar, it indicates that the coolant meets the requirement for this metric.

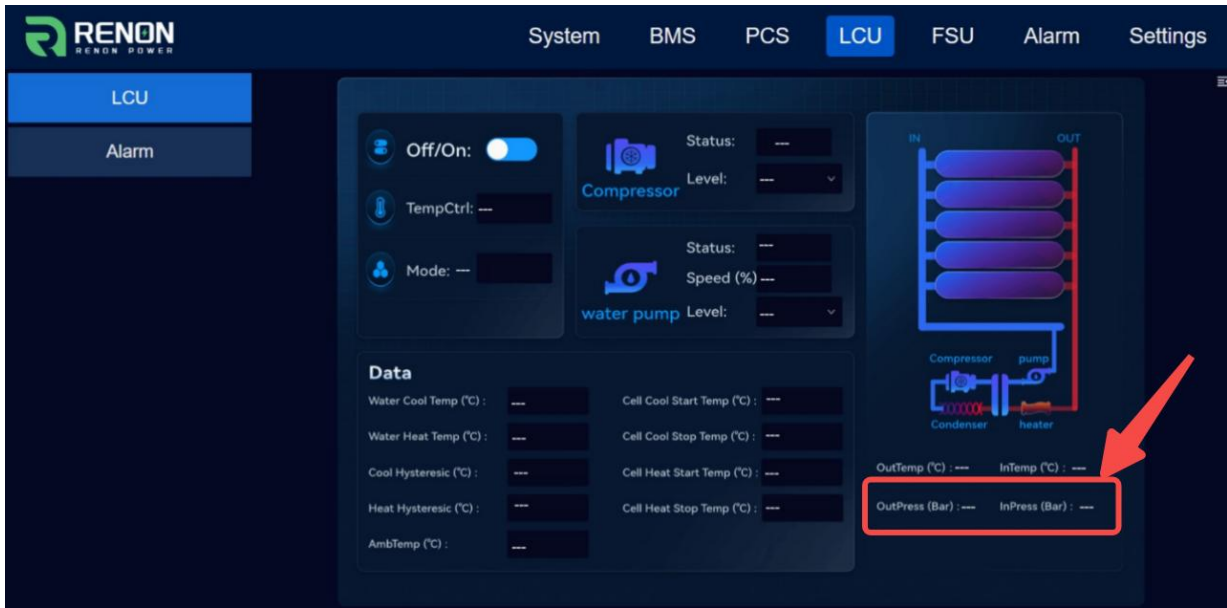

### 3. Abnormal Indicator Handling

Refer to the standards in the table below. If any indicator is abnormal, the sample shall be sent to a third-party testing institution for detailed analysis. If the test results continue to show abnormal indicators, the coolant must be replaced.

Indicator	Parameter	Unit
Odor	No pungent odor	/
pH	≥7	/
Electrical Conductivity	2000 - 4000	μS/cm
Turbidity	<5	NTU
Pressure	< 10 (refers to the pressure value during operation)	bar

### 4. Instrument Recommendations

Instrument	Recommended Instrument Brands
Portable pH/ Conductivity Meters	Mettler Toledo, Thermo Fisher Scientific, Leici
Turbidity meter	Hach, Herbwell Water, Lianhua Technology

## Technical Support

Email: [support@renon-usa.com](mailto:support@renon-usa.com)

---

### Renon Power USA LLC

580 McIntyre Rd. McKinney, TX 75071

---

### Renon Power Technology B.V.

Rietbaan 10, 2908 LP Capelle aan den IJssel

---

### Renon Power 株式会社

東京都中央区日本橋箱崎町 20-5 VORT 箱崎 5F



LinkedIn



Website